

Reader Letters



Here's a photo of a sidewalk edger I made from an old tiller. The tiller was ruggedly built and had a good engine.

I removed the left side of the shaft that drove the tines and took all the tines off the other end of the shaft except four. I turned these around on the shaft. This way, they can cut right up to the edge of the walk, using that edge for a guide. The tines rub against the walk, but will not catch on it.

To keep it at the right cutting depth, I added a gauge wheel from the deck height adjustment on an old riding lawn mower. The tiller had variable V-belt pulleys on it for forward and reverse. I changed it to go forward only and put on a different V-belt and made a belt tightener out of the old pulley. I attached a short length of cable to the old forward/reverse lever so I can use it to tighten the belt. **(Milton Nesiba, 910 Padua Ave., Ravenna, Neb. 68869)**

I built this 4 1/2 by 8-ft. fifth wheel trailer to go behind my 4-wheeler, using mostly materials I had on hand. The frame is 1 1/2-in. square steel tubing. I used 2-in. pipe to make the tandem axles. I had to



buy the spindles, but I had the tires and wheels. The floor is covered with plywood. The fifth wheel hitch I made from 1 1/2-in. round steel pipe.

I'm retired and have a small place and 25 head of ewes. I use the trailer to haul various things around the place, like lumber and supplies and hay to feed my ewes.

I've also displayed it in parades. The photo was taken at the Pioneer Days parade in Crawford, Colorado. **(Wes Edwards, 3981 J 75 Dr., Paonia, Colo. 81428 (ph 970 527-3890))**



To stabilize my Allis Chalmers 12H riding mower while cutting along road ditches, I made a stabilizer bar from steel pipe and a 10-in. wheel, like the ones used

on children's wagons.

I measured the pipe so the wheel would extend 2 ft. beyond the 4-ft. mower deck and then welded two pieces together to make a V. The rear of the V fastens to the tractor frame just in front of the gearshift. For the front, I attached one side of a door hinge to the hood of the tractor and flattened out the tube so I could fasten the other side of the hinge to that. It lets the bar follow the terrain, but because of the angle of the hinge, it won't flip up completely, so it supports the tractor if it tips a little. I found that when I mowed long grass, it caught on the bar, so I made a deflector for it. I still have to shift my weight so I can keep traction on the uphill wheel, but the stabilizer bar makes me feel a lot more secure when mowing on steep banks. **(Kenneth Haakenson, 10612 W. County Rd. M, Evansville, Wis. 53536 ph 608 882-4872)**

We at Pache Industries LLC, Norfolk, Nebraska, wanted to let you know we have purchased the Buffalo, Henke, and Kingsman lines of equipment formerly produced by Fleischer Manufacturing, Inc., Columbus, Nebraska, which ceased operation on July 5. The new company, Henke Machine • Buffalo Equipment, was open for business as of September 11, 2001

At this time, we will continue manufacturing the Henke, Buffalo and Kingsman machines at the Columbus plant formerly operated by Fleischer Manufacturing.

We intend to retain all former dealers, so if you have questions or need parts, please contact your local dealer. If you need to contact the company, the address for Henke Machine • Buffalo Equipment remains the same as it was before: 2281 16th Ave., Columbus, NE 68602. New telephone numbers are: 800 228-1405 or 402 562-0014. **(Douglas L. Stevens, Manager, Pache Industries, LLC)**

I have a muddy creek that runs through my pasture during wet seasons. I needed a way to allow cattle to cross without



getting stuck so I made a heavy wood frame out of 2-in. planks. It lays flat on the mud so it can stand a lot of weight. I drove a steel post in at each corner and ran a light chain from the platform to each post to keep it from floating away when the water runs 3 to 4 ft. deep.

I drive across it with a 4-wheeler and the cattle got used to it real fast. **(Eldon Harvey, 26173 Link Rd., Ft. Pierre, S.Dak. 57532)**

During the winter when feeding cattle, we used to need two people – one to drive the tractor and the other to ride on the bale wagon behind. If one person tried to do it, he would be continually jumping

on and off the tractor.

I decided to eliminate the problem by making my own remote-controlled steering system. I started with my son's radio-controlled jeep, removing the receiver and the servo. I then found an old 12-volt windshield wiper motor at a local garage, along with the clockwise and counter clockwise control terminals. I bought a metal kit box, 3 by 6-in. in size, and mounted the receiver, antenna, and the servo from the toy jeep in it. The receiver unit switches the servo from the clockwise to the counter clockwise contacts. Wiring runs out of the box to the windshield wiper motor, which mounts on a bracket and direct-drives a pair of rubber model airplane tires. To turn the tractor steering wheel, I just lower a set of wheels over the edge of the steering wheel.

The control box with antenna mounts with velcro to the cab window. I mounted a power plug on the fender of the tractor so we can plug the unit in easily with no need for batteries (except in the sending unit). I had to install three resistors in the control box to reduce the 12 volt power down to 9 volts, which is what the toy car motor runs on.

To feed cattle, I lower the rubber wheels over the steering wheel and climb onto the wagon. The sending unit fits in my pocket. It lets me steer the tractor by moving the joy stick right or left as the tractor creeps along. I plan to add a kill switch to the sending unit which will stop the tractor, if needed.

This invention freed up one person and eliminated many hazardous steps climbing on and off the tractor while feeding. **(Jack Vernon, Vernon Ranch, HC 10, Box 520, Lakeview, Ore. 97630 ph 541 947-4804)**

To push over tall sudan grass or other tall weeds when running a rotary mower, I drag a small wood post under the tractor. All I do is run two small chains back from

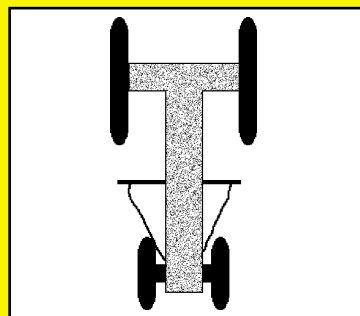

the front of the tractor to the post. It pushes over the grass, helping keep pollen from the operator and making mowing easier. **(Lloyd Lockhart, Bern, Kan. 785 336-3974)**

Editor's Note: A letter to the editor in the last issue of FARM SHOW talked about how using red plastic mulch on tomatoes can increase production from 13 to 20 percent. There was a phone number for buying red plastic but, unfortunately, the phone number was wrong.

Here's the correct name, address and phone: **Ken-Bar Products, 25 Walkers Brook Dr., Reading, Mass. 01867 (ph 800-336-8882)**

Response to your article on our Liftguard (TM) combination rock guards and crop lifters far exceeded what I had imagined. While the article clearly stated that I had only tested them in my wild rice crop and was looking for a manufacturer, most callers, many of whom spoke in terms of sections of land rather than acres, said



they needed no further testing to know that the Liftguards were what they needed, and they hoped I could sell them to them. A dealer who wrote assumed the Liftguards were already in production and asked me to supply his several retail outlets.

I regret that I am not able to provide Liftguards to everyone who has requested them at this time, but as a result of the article, I have been communicating with several potential manufacturers in the U.S. and Canada and I'm hopeful we'll have them available for next year.

In the meantime, I have decided I will try to make as many as I can for those who need them right away. I'm charging \$19.00 each for new guards I convert in my shop. If a farmer wants to send me his existing sickle guards, I can work with them and the price will be reduced to \$14.95 each. I'll need to know the machine model, the number of guards currently on the sickle, preferred spacing, total number of guards wanted, and when they're needed.

I'm hoping we'll be able to put the factory-produced Liftguards on the market for around \$15, once we have worked things out with a manufacturer. **(Joe Figliuzzi, HC 70 County Rd 23, Kelliher, Minn. 56650 ph 218 647-8529; E-mail: joefig@paulbunyan.net)**

Our new pine straw harvesting machines, introduced at the recent Sunbelt Expo near Moultrie, Ga., allow farmers and homeowners to rake and bale pine straw.



The machines include a self-propelled, hydraulic-driven, 52-in. wide rake, and a 3-pt. mounted, pto-driven round baler. The baler makes bales that measure 15 in. in diameter and 24 in. long. The bales weigh 18 to 24 lbs. so they're easy to handle. An audible signal on the baler tells you when the chamber is full.



The self-propelled rake is powered by an 8 hp air-cooled gas engine and has a pair of gauge wheels. Cranks are used to regulate ground clearance. A horizontal tree protector wheel on the right side of